

REMA Anschlagwirbel mit Spannbügel C806X (Güteklasse 10)

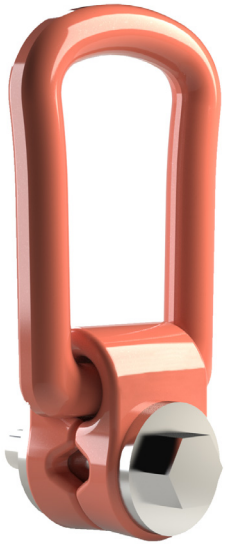

Merkmale

- 360 ° drehbar, 90 ° klappbar und tragfähig.
- Unter Last nicht drehbar.
- 4-fache Sicherheit in Lastrichtung.
- Nach EN 1677-1.

Norm:

- GS-OA 15-04 / EN1677

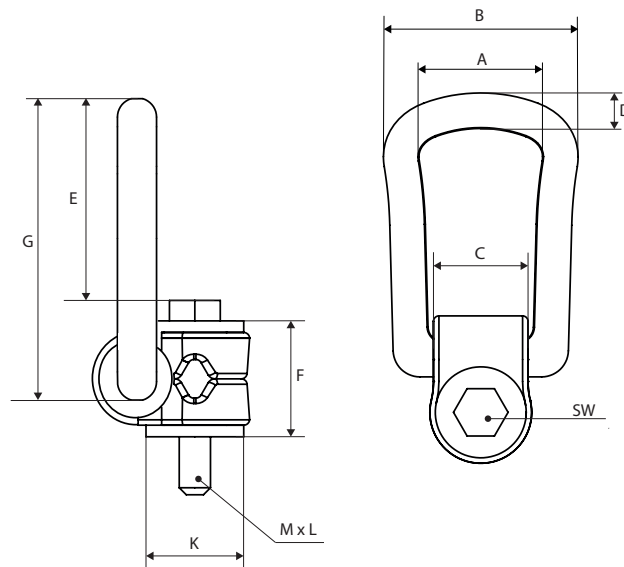

Typ	Tragfähigkeit (kg)	A (mm)	B (mm)	C (mm)	D (mm)	E (mm)	G (mm)	K (mm)	M (mm)	L (mm)	SW (mm)	Gewicht (kg/st/m)	Artikel-Nr.
C806X-M8x15-0.3T	300	34	57	24	10	43	78	25	M8	15	13	0,275	2611208
C806X-M10x15-0.63T	630	34	57	24	10	42	78	25	M10	15	17	0,290	2611210
C806X-M12x23-1.0T	1.000	38	66	30	13.5	40	85	32	M12	23	19	0,500	2611212
C806X-M16x24-1.5T	1.500	38	66	30	13.5	38	85	32	M16	24	24	0,510	2611216
C806X-M20x31-2.5T	2.500	55	87	48	16	54	111	45	M20	31	30	1,250	2611220
C806X-M24x37-4.0T	4.000	55	87	48	16	51	111	45	M24	37	36	1,300	2611224
C806X-M30x45-5.0T	5.000	66	109	54	22.5	62	145	60	M30	45	46	3,250	2611230
C806X-M36x50-7.0T	7.000	66	109	54	22.5	60	145	60	M36	50	55	3,300	2611236
C806X-M42x75-10T	10.000	78	136	62	28	86	190	70	M42	75	65	6,500	2611242
C806X-M42x63-15T	15.000	97	169	68	36	121	242	85	M42	63	65	11,200	2611243
C806X-M48x71-20T	20.000	97	169	68	36	117	242	95	M48	71	75	11,600	2611248